

8

7

6

5

4

3

2

1

PS20F

NOTE: COMPOSITE POSITION TOLERANCES SHOWN ARE RECOMMENDED
 MINIMUM FOR THE HOLE PATTERN (UPPER SEGMENT = .007"), AND REQUIRED
 MINIMUM FOR THE HOLE FEATURES (LOWER SEGMENT = .001") TO ENSURE
 ADEQUATE ALIGNMENT WITH ROCKLOCK BASES.

PS16F

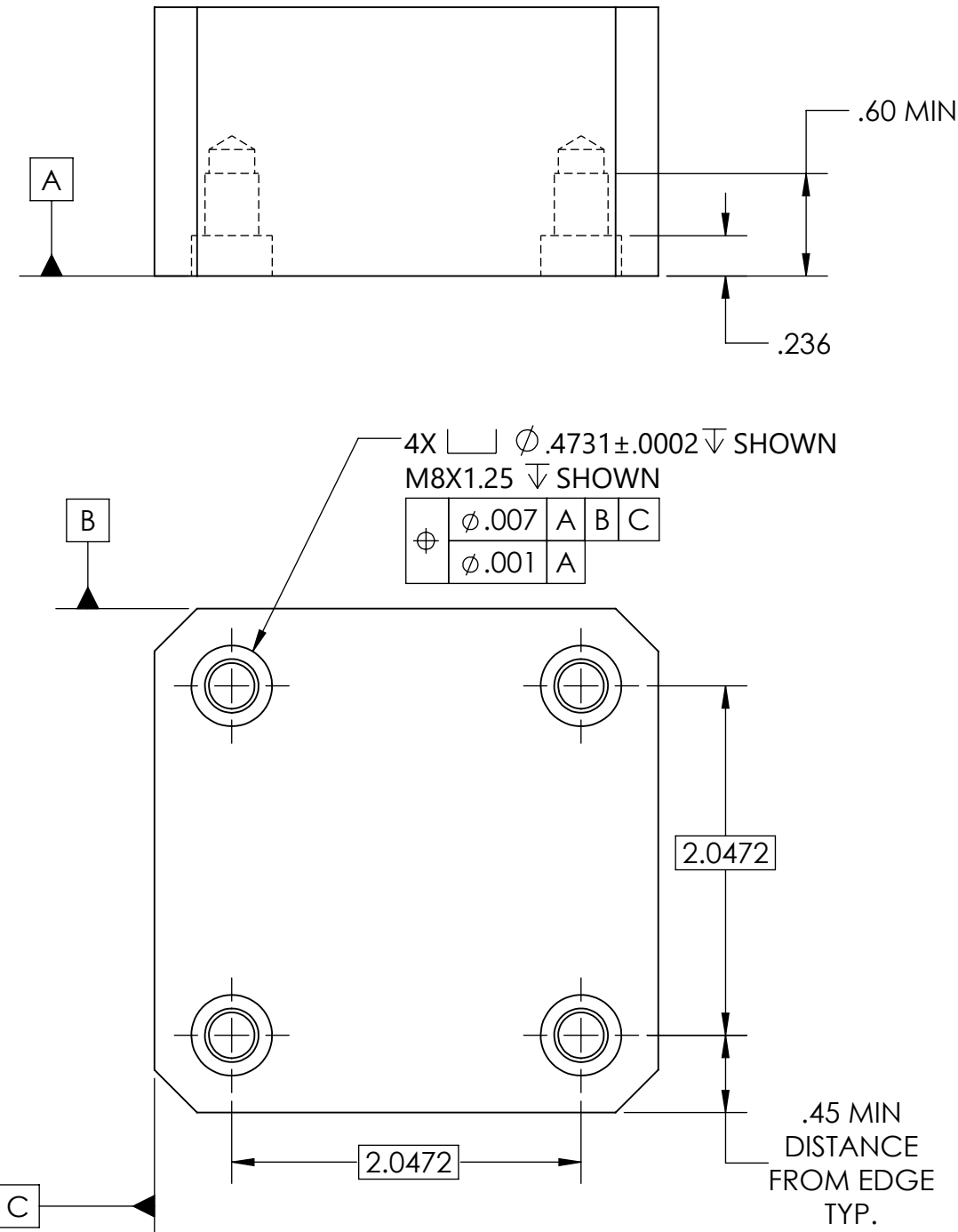
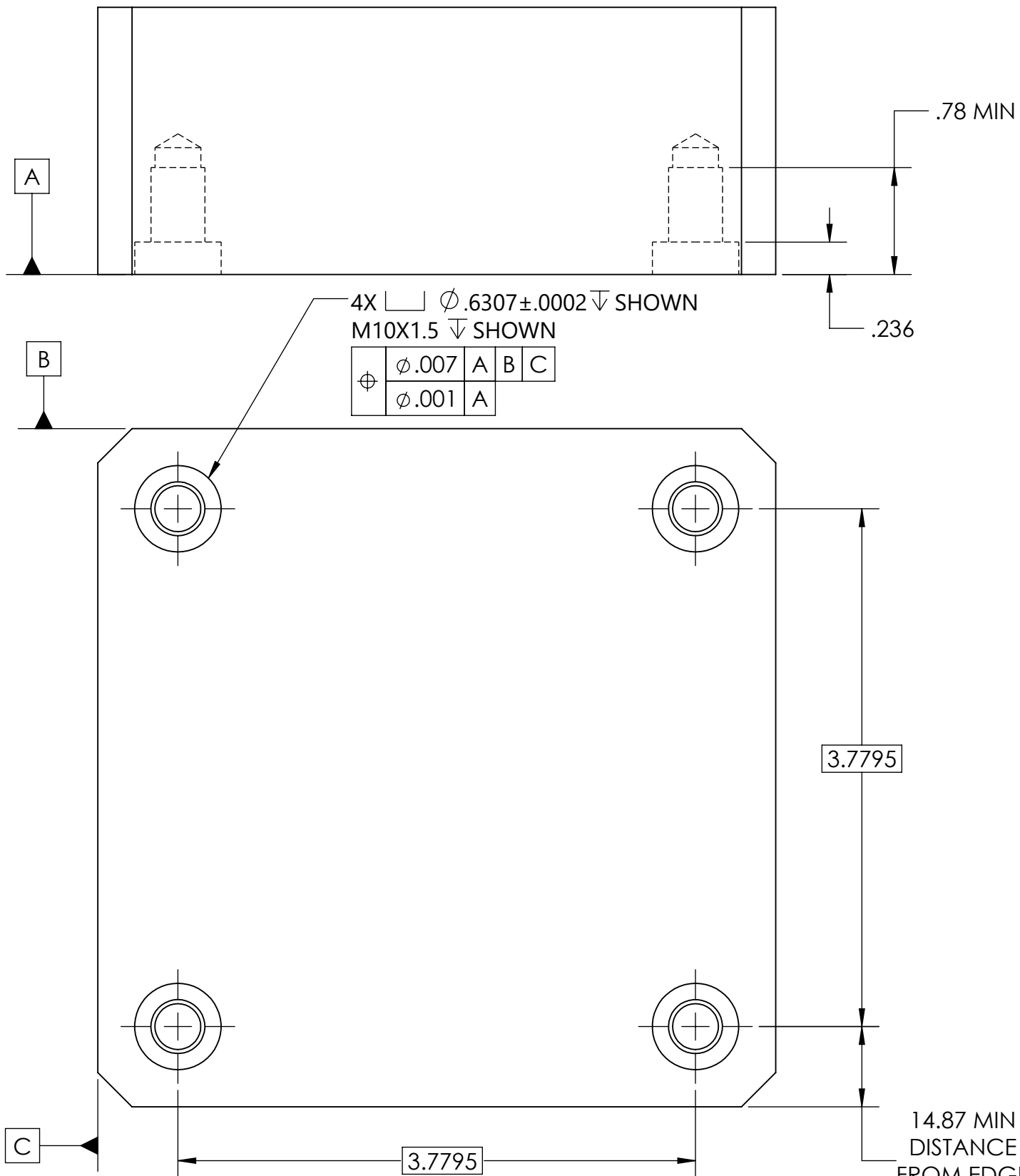

INCH			
WWW.5THAXIS.COM			
7140 ENGINEER ROAD SAN DIEGO, CA 92111 P (858) 505-0432		DESCRIPTION PS20F/PS16F HOLE CALLOUT FOR CUSTOM TOOLING	
THIRD ANGLE PROJECTION	SIZE B	PART NO.	REV C
DO NOT SCALE DRAWING		SCALE 1:1	WEIGHT:
		SHEET 1 OF 1	

8

7

6

5

4

3

2

1

D

D

C

C

B

B

A

A

8

7

6

5

4

3

2

1

PS20F

NOTE: COMPOSITE POSITION TOLERANCES SHOWN ARE RECOMMENDED
 MINIMUM FOR THE HOLE PATTERN (UPPER SEGMENT = .178mm), AND
 REQUIRED MINIMUM FOR THE HOLE FEATURES (LOWER SEGMENT = .025mm) TO
 ENSURE ADEQUATE ALIGNMENT WITH ROCKLOCK BASES.

PS16F

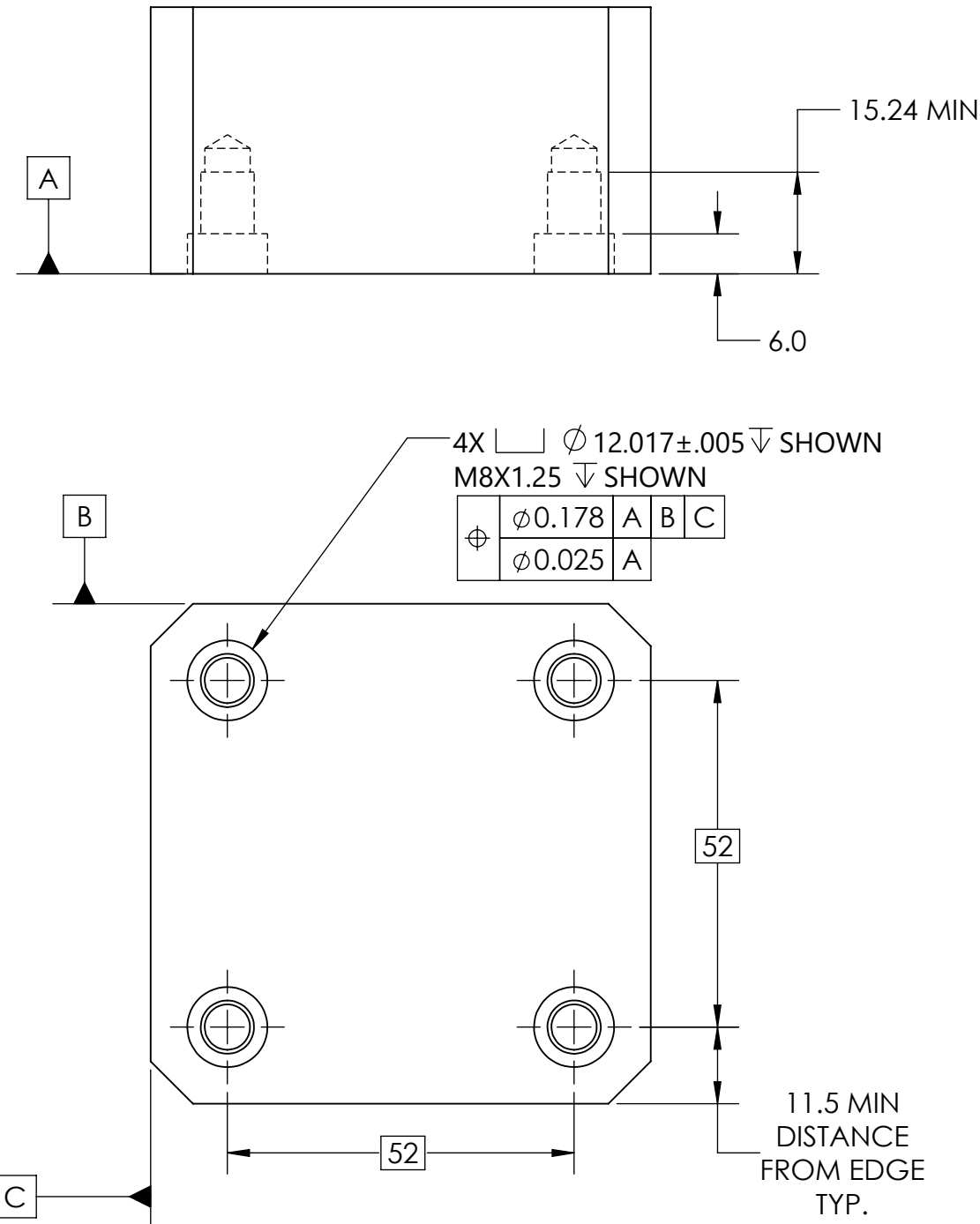
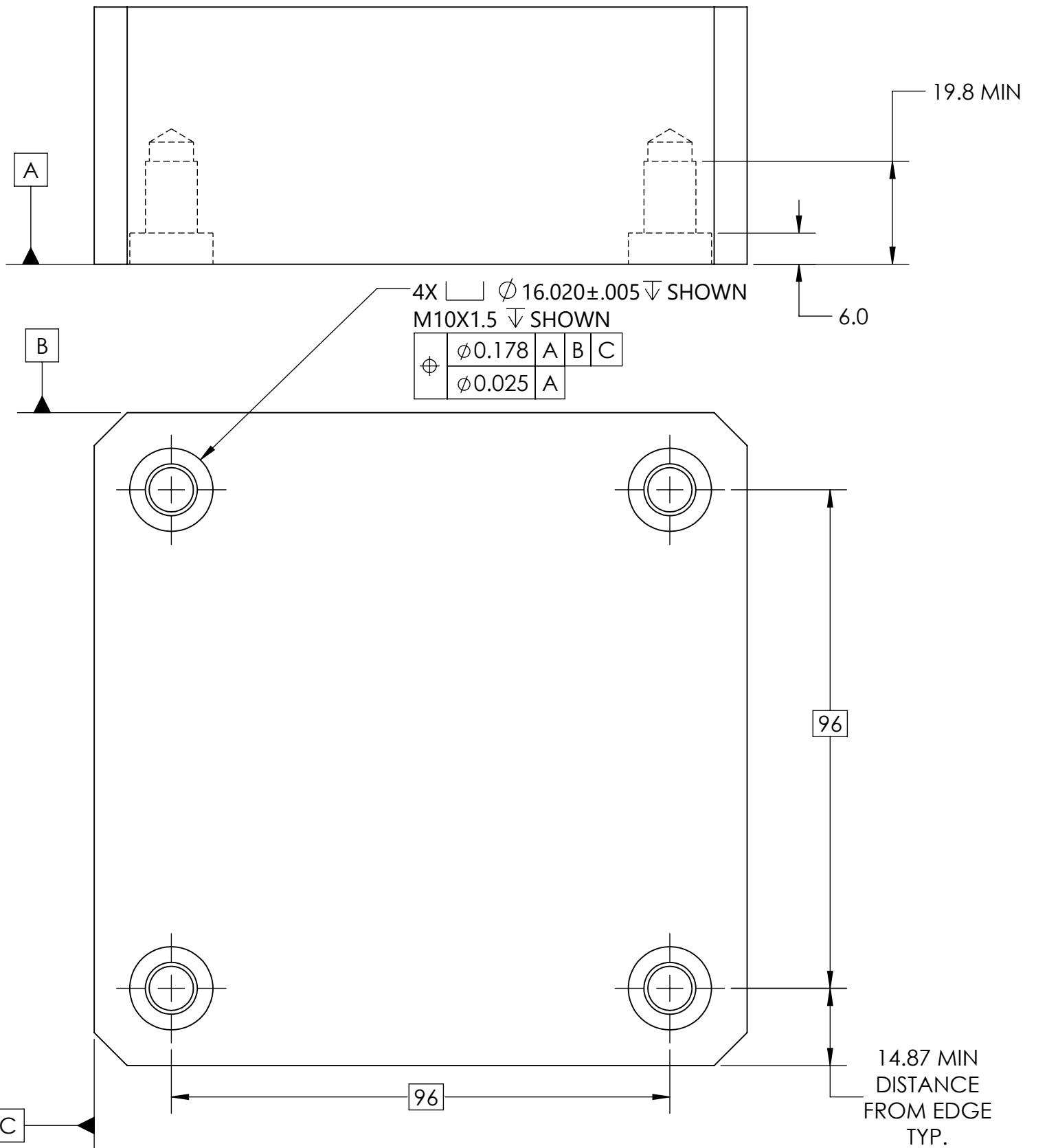

MILLIMETER WWW.5THAXIS.COM 7140 ENGINEER ROAD SAN DIEGO, CA 92111 P (858) 505-0432			
	DESCRIPTION PS20F/PS16F HOLE CALLOUT FOR CUSTOM TOOLING		
THIRD ANGLE PROJECTION 	SIZE B	PART NO. PULL STUD HOLE PREP	REV C
DO NOT SCALE DRAWING	SCALE 1:1	WEIGHT:	SHEET 1 OF 1

8

7

6

5

4

3

2

1