

8

7

6

5

4

3

2

1

TECHNICAL DATA	DV56-J2
JAW WIDTH	125.73mm
BASE LENGTH	152.4mm
MAXIMUM TORQUE (JAW BOLT)	47 Nm
CLAMPING FORCE	25 kN @ 75 Nm
MAXIMUM TORQUE (LEADSCREW)	75 Nm
MAXIMUM TORQUE (MOUNTING BOLT)	47 Nm
SELF-CENTERING ACCURACY	± 12.7 μm

DV56-J2

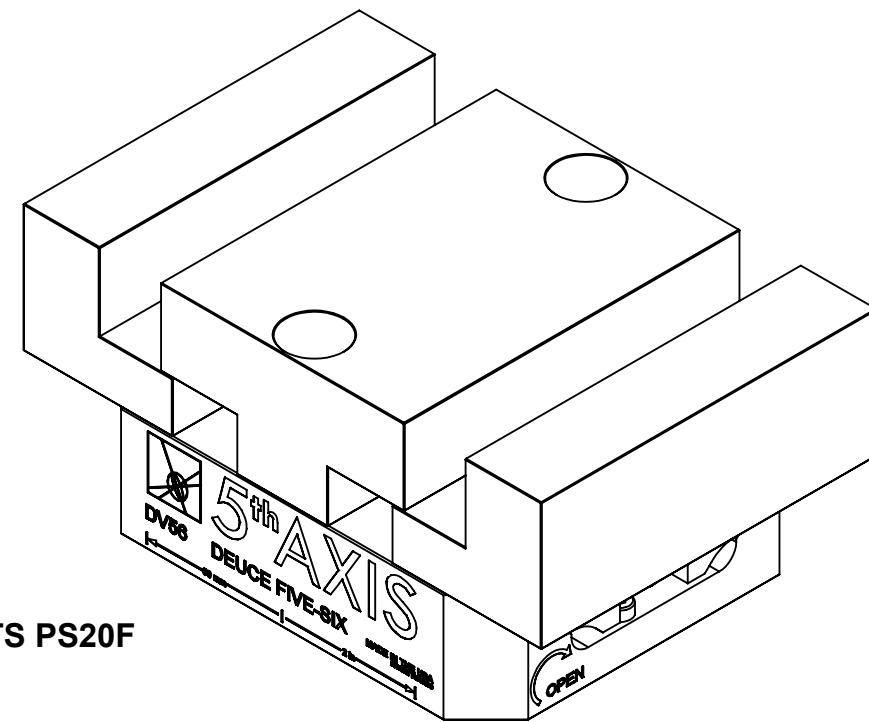

D

D

C

C

B

B

A

A

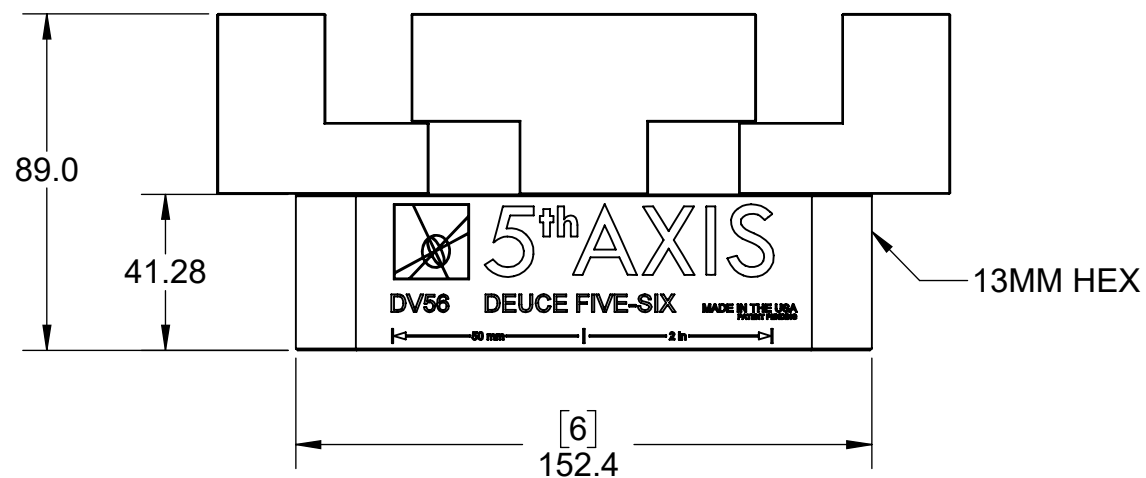
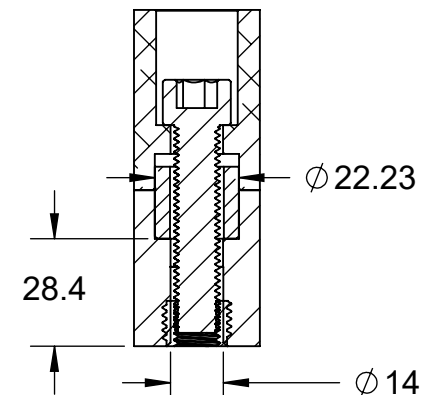
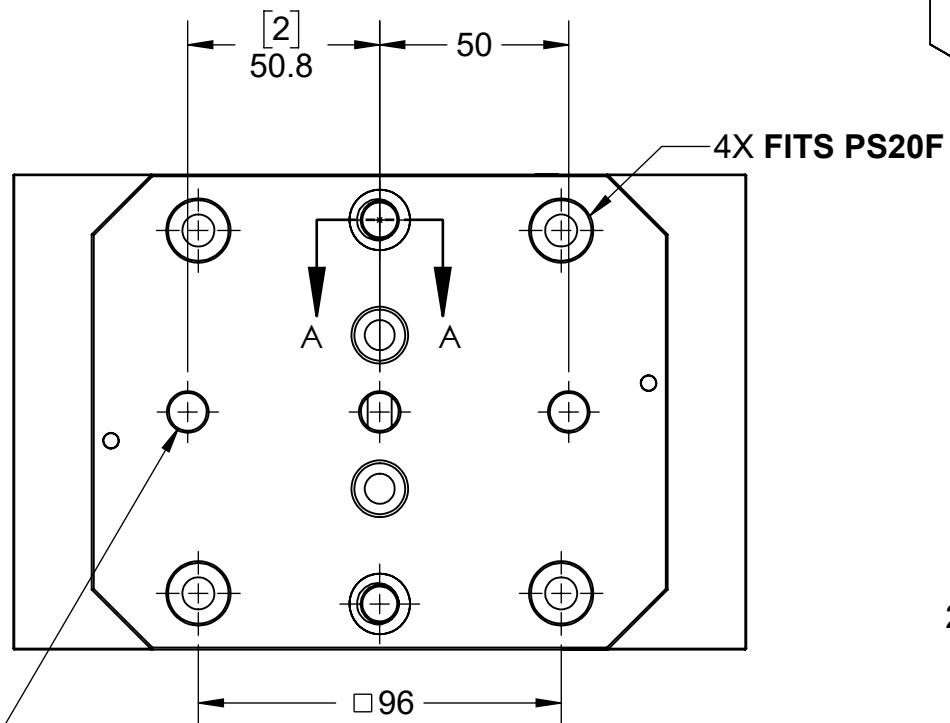
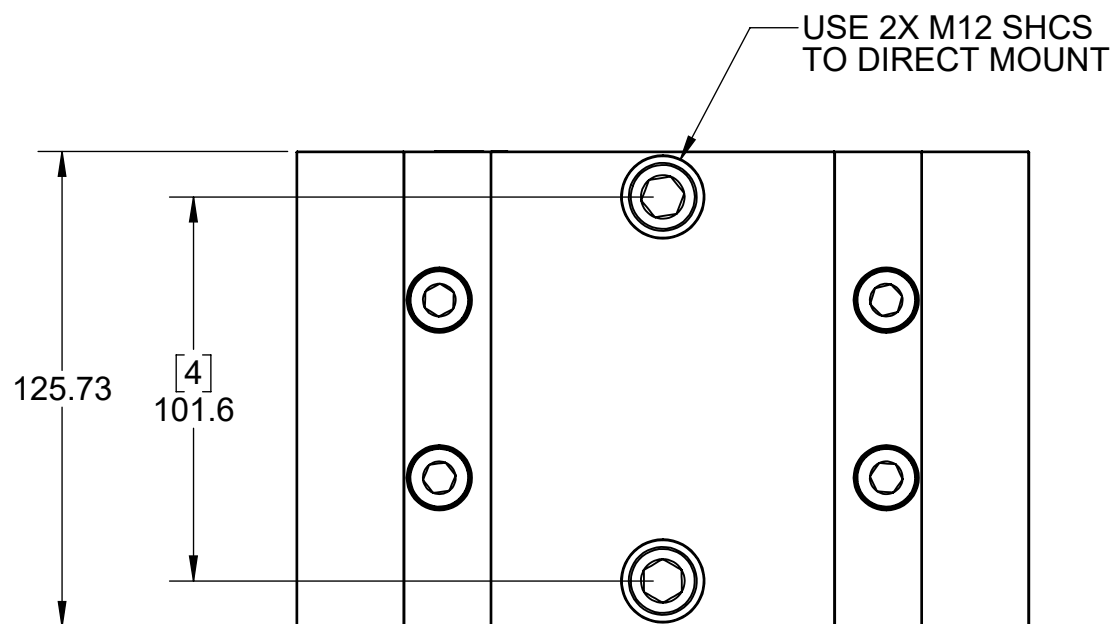

MILLIMETER WWW.5THAXIS.COM 7140 ENGINEER ROAD SAN DIEGO, CA 92111 P (858) 505-0432			
	DESCRIPTION MEDIUM DOUBLE STATION VISE WITH ALUMINUM SOFT JAWS		
THIRD ANGLE PROJECTION	SIZE B	PART NO. DV56-J2	REV B
DO NOT SCALE DRAWING		SCALE 1:2	WEIGHT:
		SHEET 1 OF 4	

8

7

6

5

4

3

2

1

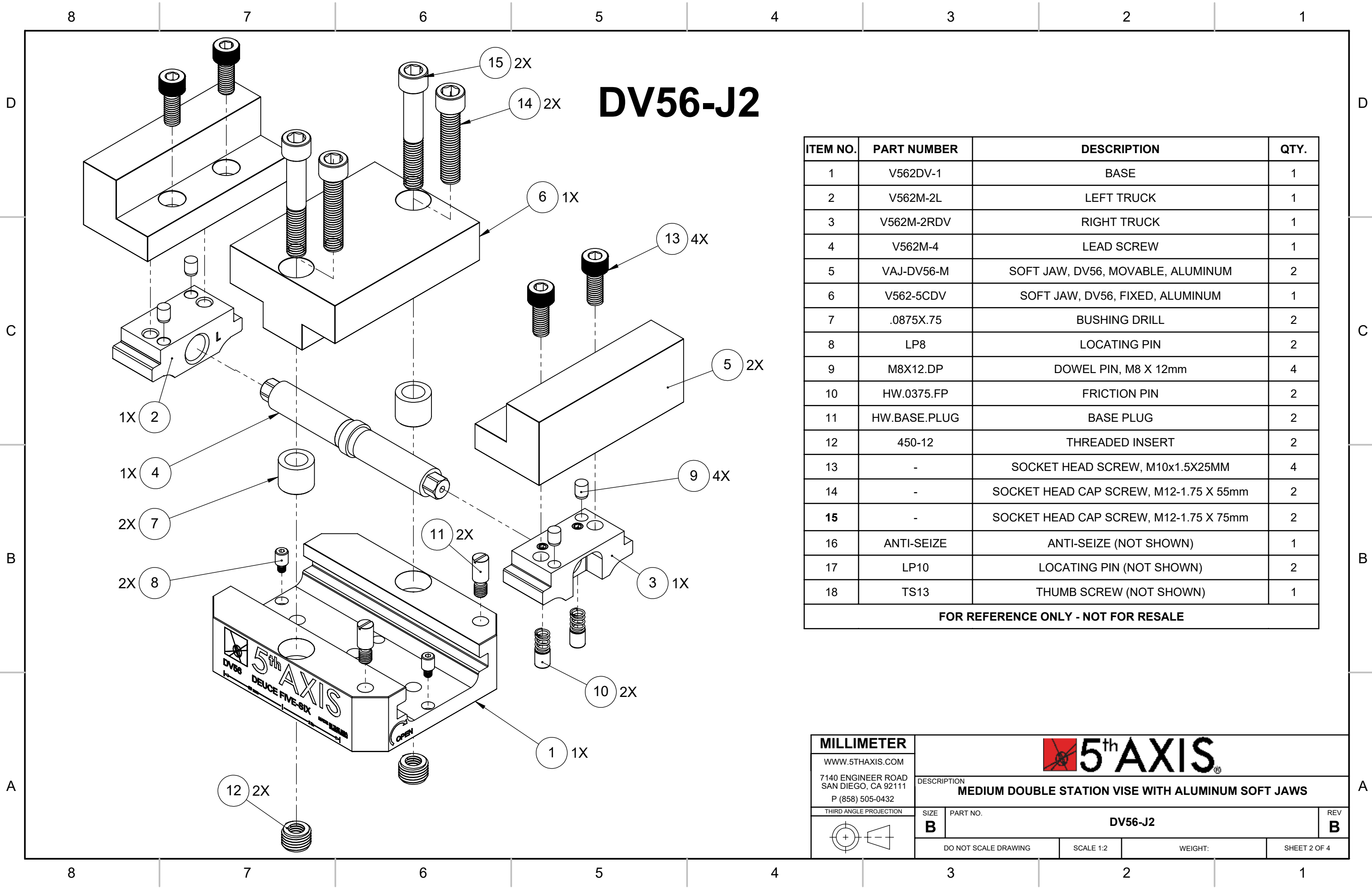

DV56-J2

ITEM NO.	PART NUMBER	DESCRIPTION	QTY.
1	V562DV-1	BASE	1
2	V562M-2L	LEFT TRUCK	1
3	V562M-2RDV	RIGHT TRUCK	1
4	V562M-4	LEAD SCREW	1
5	VAJ-DV56-M	SOFT JAW, DV56, MOVABLE, ALUMINUM	2
6	V562-5CDV	SOFT JAW, DV56, FIXED, ALUMINUM	1
7	.0875X.75	BUSHING DRILL	2
8	LP8	LOCATING PIN	2
9	M8X12.DP	DOWEL PIN, M8 X 12mm	4
10	HW.0375.FP	FRICTION PIN	2
11	HW.BASE.PLUG	BASE PLUG	2
12	450-12	THREADED INSERT	2
13	-	SOCKET HEAD SCREW, M10x1.5X25MM	4
14	-	SOCKET HEAD CAP SCREW, M12-1.75 X 55mm	2
15	-	SOCKET HEAD CAP SCREW, M12-1.75 X 75mm	2
16	ANTI-SEIZE	ANTI-SEIZE (NOT SHOWN)	1
17	LP10	LOCATING PIN (NOT SHOWN)	2
18	TS13	THUMB SCREW (NOT SHOWN)	1

FOR REFERENCE ONLY - NOT FOR RESALE

MILLIMETER
 WWW.5THAXIS.COM
 7140 ENGINEER ROAD
 SAN DIEGO, CA 92111
 P (858) 505-0432
 THIRD ANGLE PROJECTION



DESCRIPTION
MEDIUM DOUBLE STATION VISE WITH ALUMINUM SOFT JAWS

SIZE **B** PART NO. **DV56-J2** REV **B**

DO NOT SCALE DRAWING SCALE 1:2 WEIGHT: SHEET 2 OF 4

8

7

6

5

4

3

2

1

D

D

DV56-J2

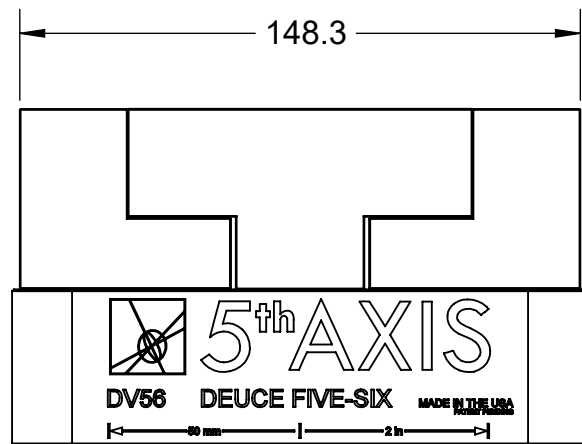

JAWS FULLY CLOSED

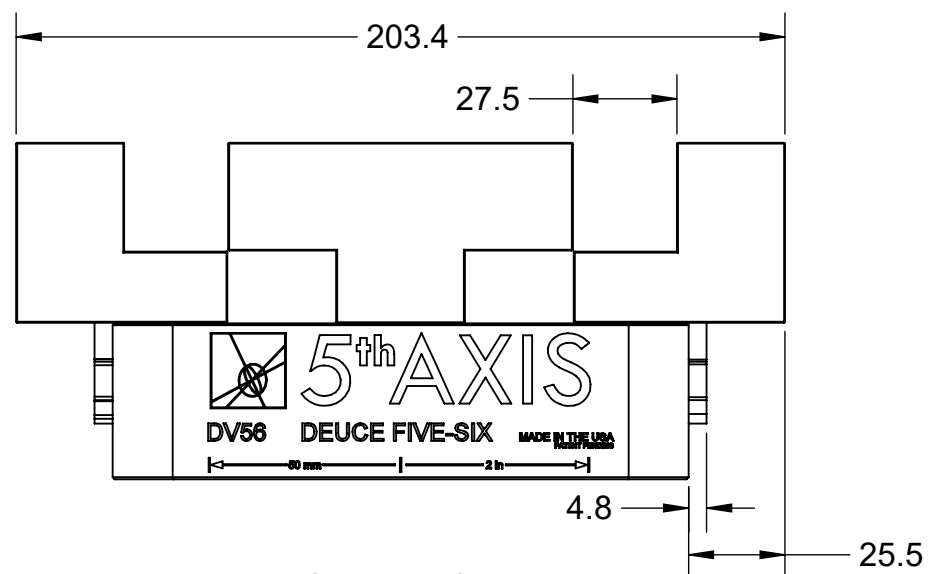

JAWS FULLY OPENED

C

C

B

B

A

A

8

7

6

5

4

3

2

1

MILLIMETER			
WWW.5THAXIS.COM 7140 ENGINEER ROAD SAN DIEGO, CA 92111 P (858) 505-0432			
THIRD ANGLE PROJECTION		DESCRIPTION MEDIUM DOUBLE STATION VISE WITH ALUMINUM SOFT JAWS	
SIZE	PART NO.	REV	
B	DV56-J2	B	
DO NOT SCALE DRAWING		SCALE 1:2	WEIGHT:
		SHEET 3 OF 4	

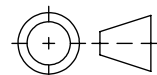

8

7

6

5

4

3

2

1

D

D

DV56-J2

C

C

B

B

A

A

CONFIGURATION FOR MOUNTING VISE TO TABLE

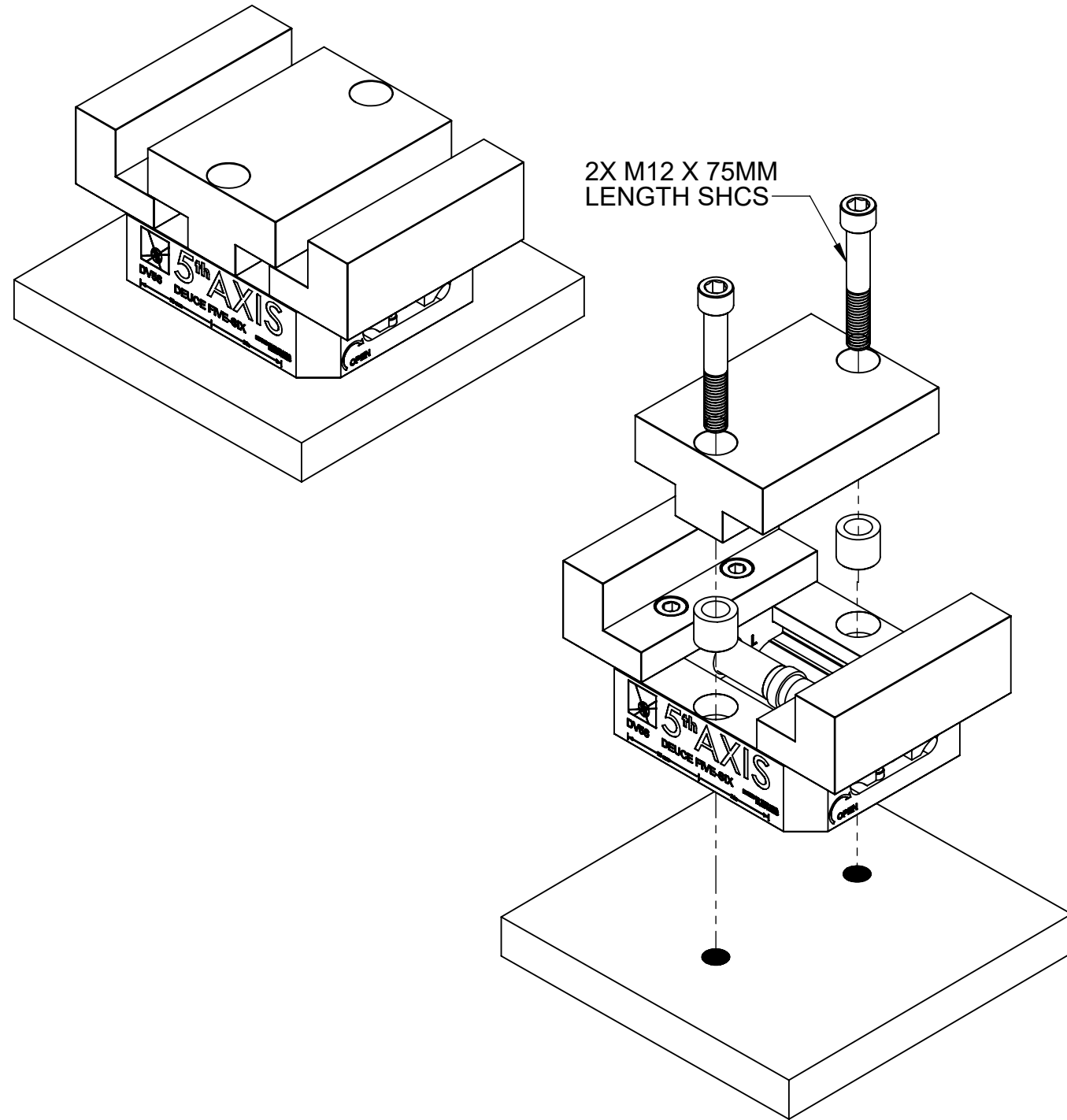

2X M12 X 75MM LENGTH SHCS

CONFIGURATION FOR MOUNTING VISE TO ROCKLOCK SYSTEM

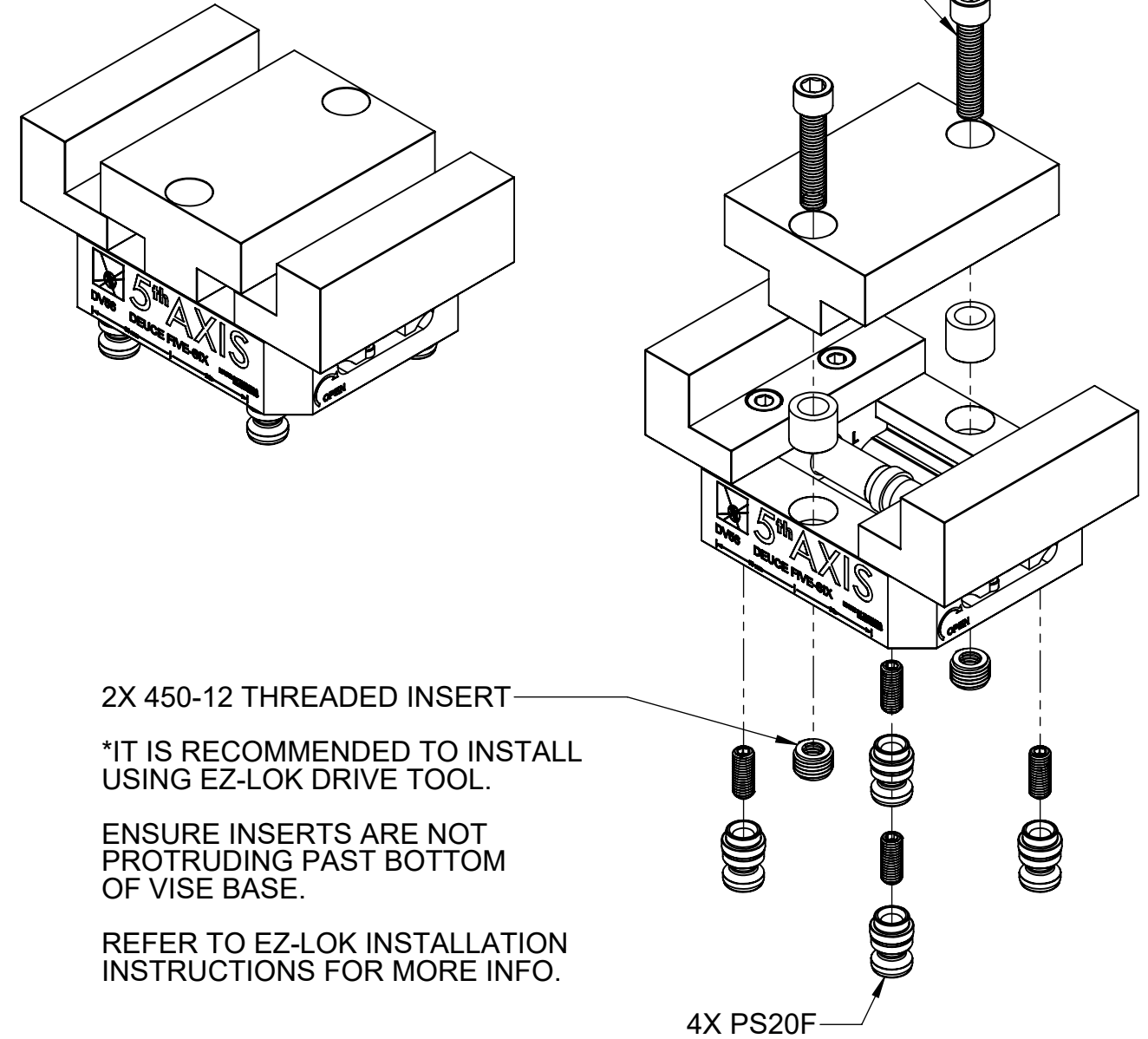

2X M12 X 55MM LENGTH SHCS

2X 450-12 THREADED INSERT

*IT IS RECOMMENDED TO INSTALL USING EZ-LOK DRIVE TOOL.

ENSURE INSERTS ARE NOT PROTRUDING PAST BOTTOM OF VISE BASE.

REFER TO EZ-LOK INSTALLATION INSTRUCTIONS FOR MORE INFO.

4X PS20F

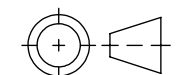
MILLIMETER				
WWW.5THAXIS.COM				
7140 ENGINEER ROAD SAN DIEGO, CA 92111 P (858) 505-0432		DESCRIPTION MEDIUM DOUBLE STATION VISE WITH ALUMINUM SOFT JAWS		
THIRD ANGLE PROJECTION 		SIZE B	PART NO. DV56-J2	REV B
DO NOT SCALE DRAWING		SCALE 1:2	WEIGHT:	SHEET 4 OF 4

8

7

6

5

4

3

2

1