

NOTES:

- 1. DOVETAIL WIDTH WILL NOT CHANGE WITH VARYING DOVETAIL DEPTH
- 2. MACHINE EDGE BREAK ON DOVETAIL POINT
- 3. SLOT DIMENSION TO THE CENTERLINE IS **CRITICAL**, IF DIMENSION IS TOO LARGE, STOCK MAY REST AGAINST LOCATING PIN INSTEAD OF DOVETAIL CUT SURFACES.
- 4. IF STOCK IS OVERSIZED, THE TOLERANCE IS INCREASED BY HALF THE EXTRA STOCK

DM12 DOVETAIL STOCK PREPARATION

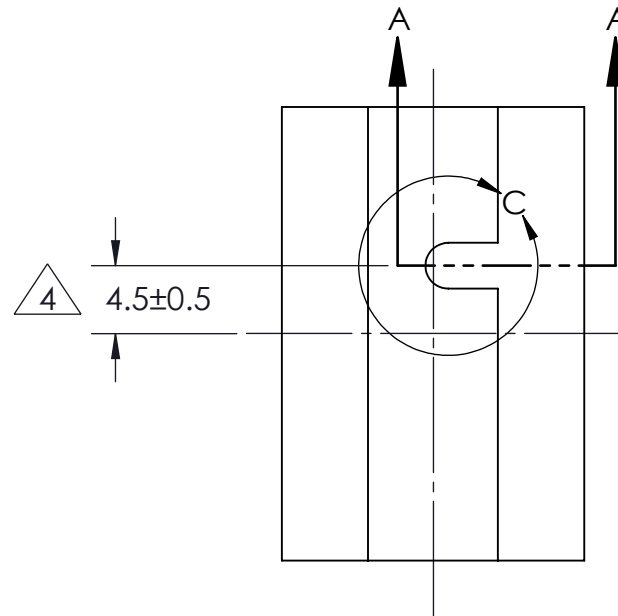
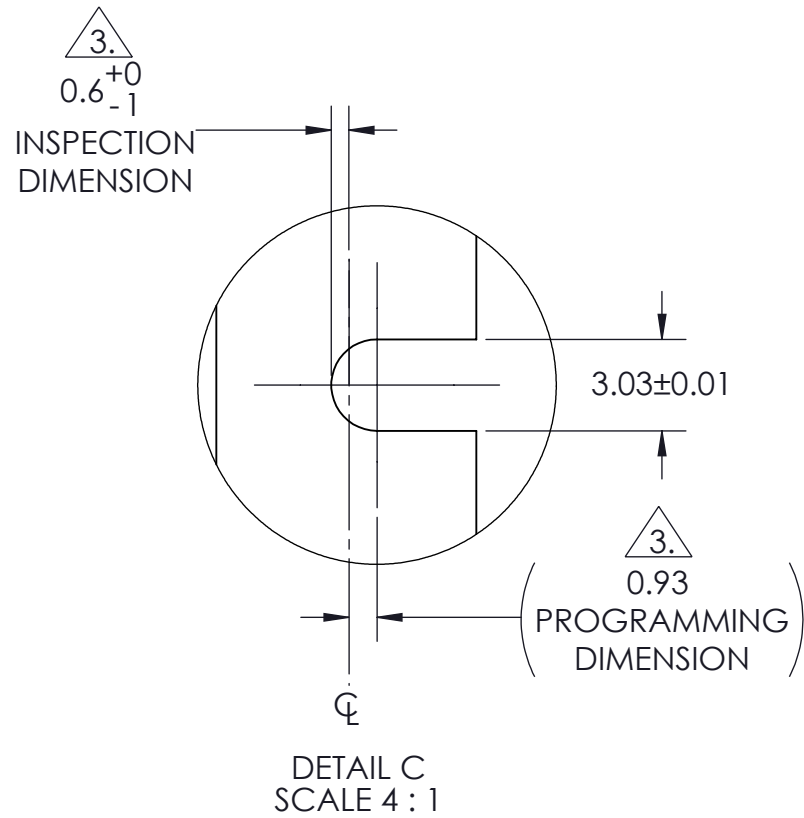
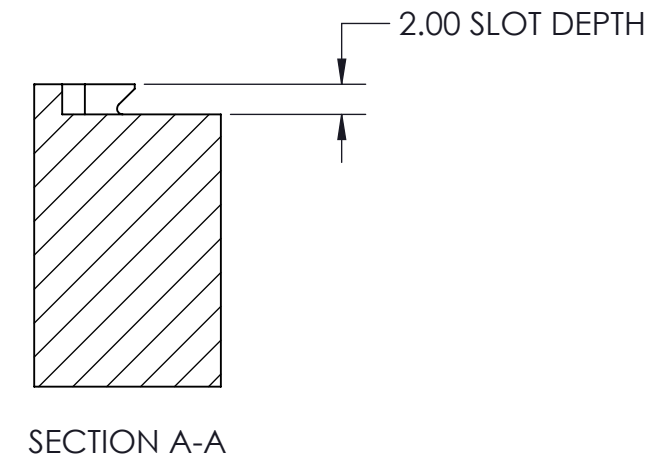
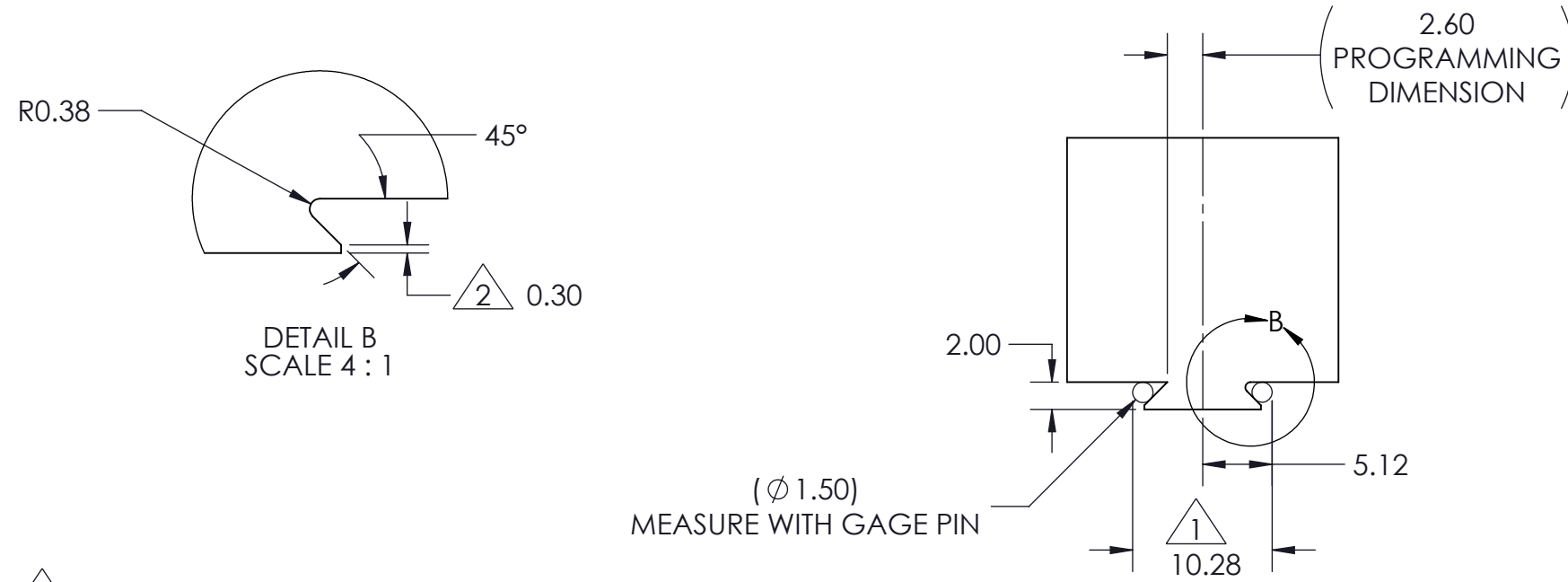

| | | | |
|---|---|-----------------|--|
| MILLIMETER <small>DRAWN IN ACCORDANCE WITH ASME Y14.5-2009</small> PROPRIETARY AND CONFIDENTIAL <small>THE INFORMATION CONTAINED IN THIS DRAWING IS THE SOLE PROPERTY OF FIFTH AXIS, INC. ANY REPRODUCTION IN PART OR AS A WHOLE WITHOUT THE WRITTEN PERMISSION OF FIFTH AXIS, INC. IS PROHIBITED.</small> | TOLERANCES <small>UNLESS OTHERWISE SPECIFIED</small> X ± 1.0 .X ± 0.3 ANGLULAR ± 0.5° .XX ± 0.13 | | <small>WWW.FIFTHAXIS.COM</small> 7140 ENGINEER ROAD SAN DIEGO, CA 92111 P (858) 505-0432 F (858) 505-9344 |
| | <small>THIRD ANGLE PROJECTION</small> | | DESCRIPTION DM12 DOVETAIL STOCK PREP |
| SIZE B | PART NO. DSP-DM12 | REV A | <small>DO NOT SCALE DRAWING</small> |



PROPER DOVETAIL

MATERIAL SHOULD REST ON TOP OF THE JAW / FIXTURE AND ON THE 45° FACE.

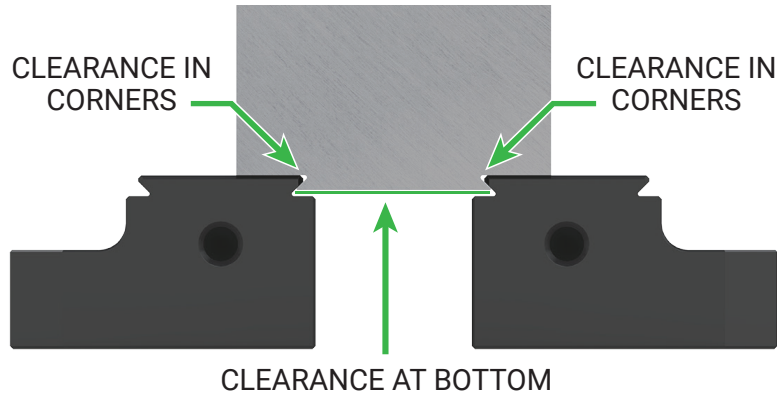

When a **proper** dovetail is used, jaw/dovetail fixture **acts as a wedge** attempting to split the material in the corner.

Material is clamped only once or twice and is therefore resistant to fracturing.

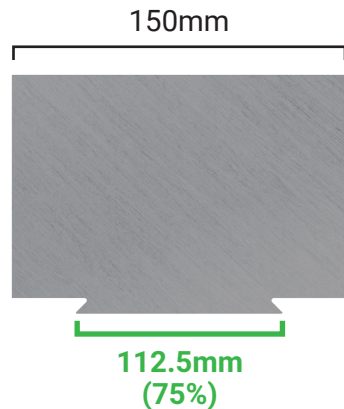
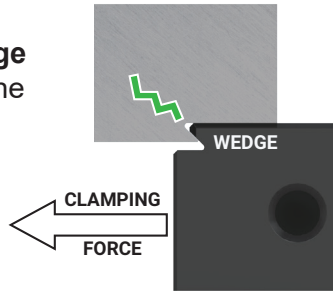

Dovetail width should not be **less than 75%** of the width of the stock.

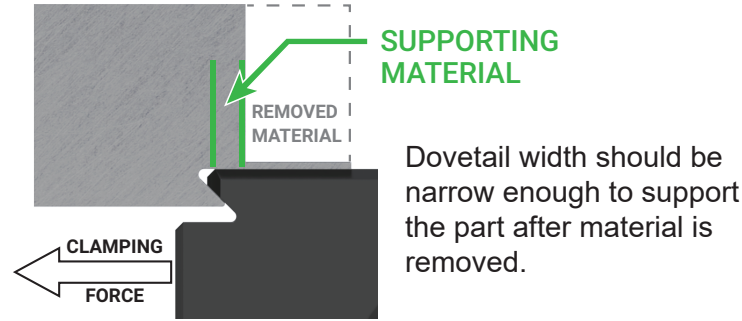

Dovetail width should be narrow enough to support the part after material is removed.

THERE IS NO SIMPLE ANSWER TO HOW MUCH SUPPORT IS NEEDED.

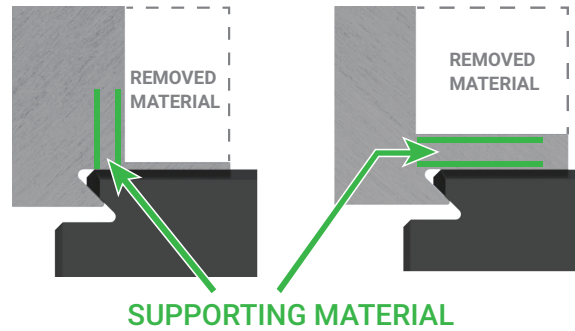

If more support is needed, **decrease dovetail width** or **increase tab thickness**.

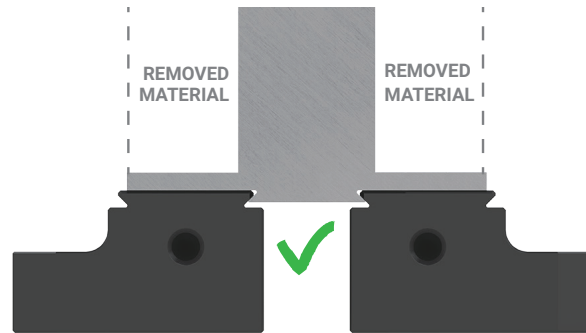

For narrow parts, position the dovetail as close as possible to the **finished part's** center of mass.



COMMON MISTAKES

❌ 1. DOVETAIL TOO DEEP

Clamping with a dovetail should **never** cause the material to locate on the bottom step of the jaw.

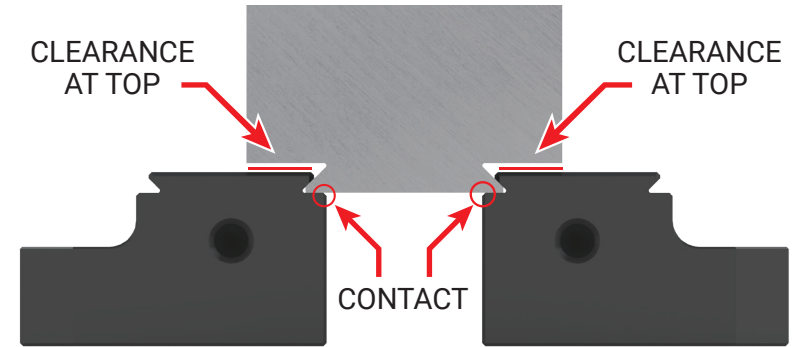

Locating on bottom step causes material to become a wedge trying to split the jaw. **This can break the jaw!**

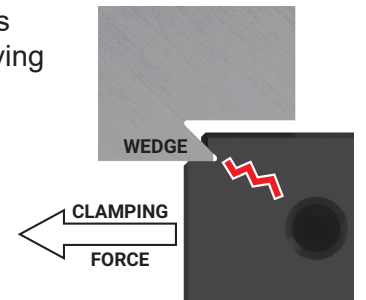

❌ 2. FINISHED PART UNSUPPORTED



A thin tab and/or insufficient material on the top locating surface will allow the part to move during machining.

✘ 3. OVERSIZED CORNER RADIUS

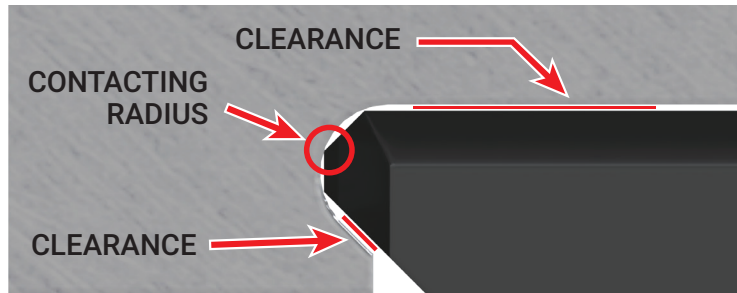

An overly wide inside corner radius allows material to contact the corner of the jaw, preventing it from locating correctly.

This will create excessive vibration during machining.

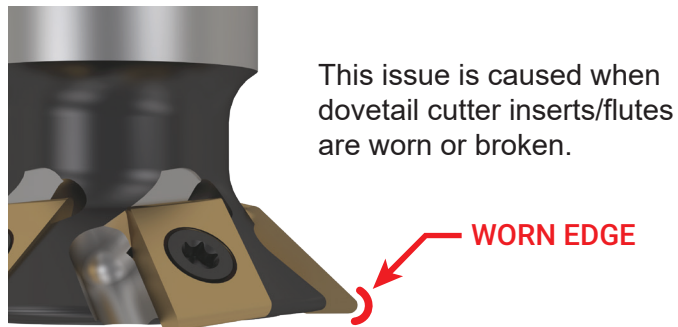

This issue is caused when dovetail cutter inserts/flutes are worn or broken.

✘ 4. EXCESSIVELY WIDE DOVETAIL

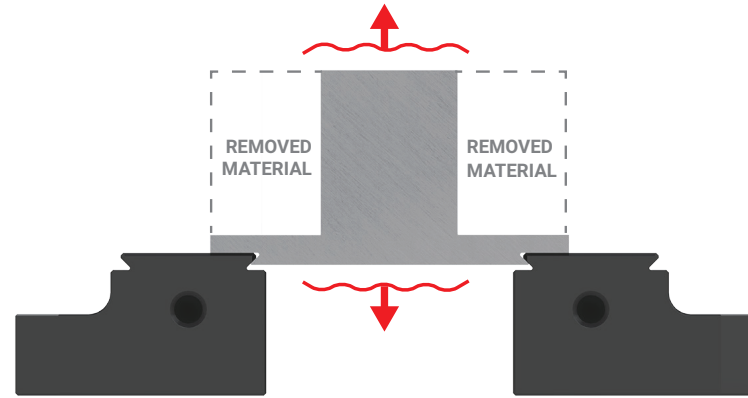

Even though this part has tabs thick enough to prevent breaking, the dovetail is not positioned correctly under the part. This may result in excessive vertical vibration.

✘ 5. EXCESSIVELY NARROW DOVETAIL

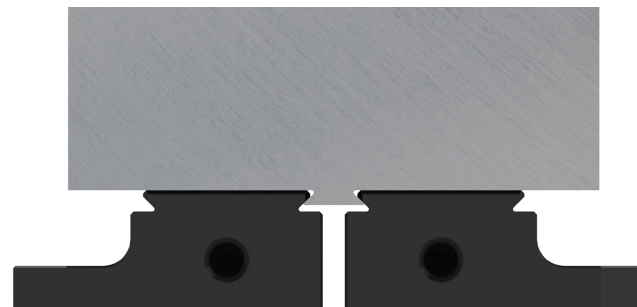

Excessively narrow dovetail will concentrate support at the center of the stock and potentially cause chatter.

Keep in mind how and where force is applied to stock during machining.



DOVETAIL TROUBLESHOOTING GUIDE



The information in this document is applicable to **ALL** 5th Axis™ products with a dovetail feature.