

A52-D22

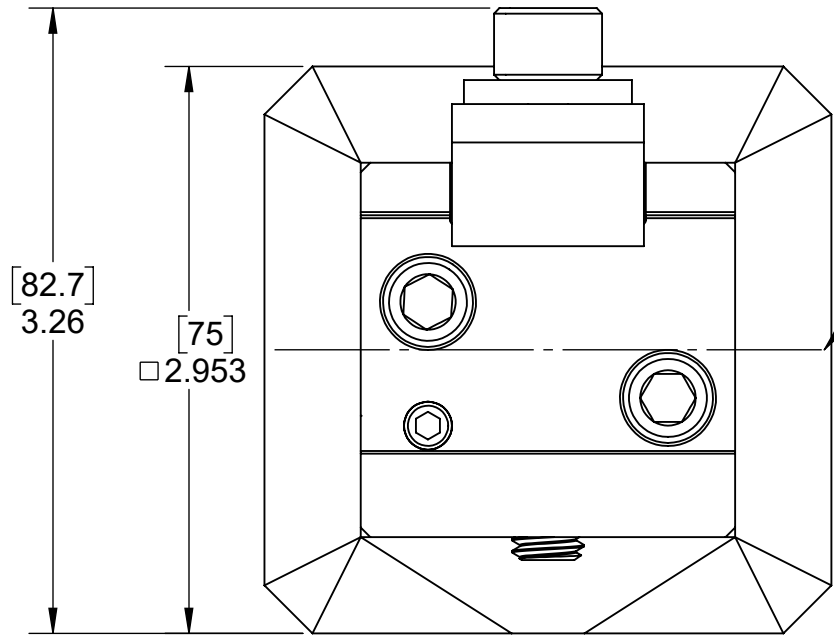

DOVETAIL ϕ
ALIGNED WITH
BASE ϕ

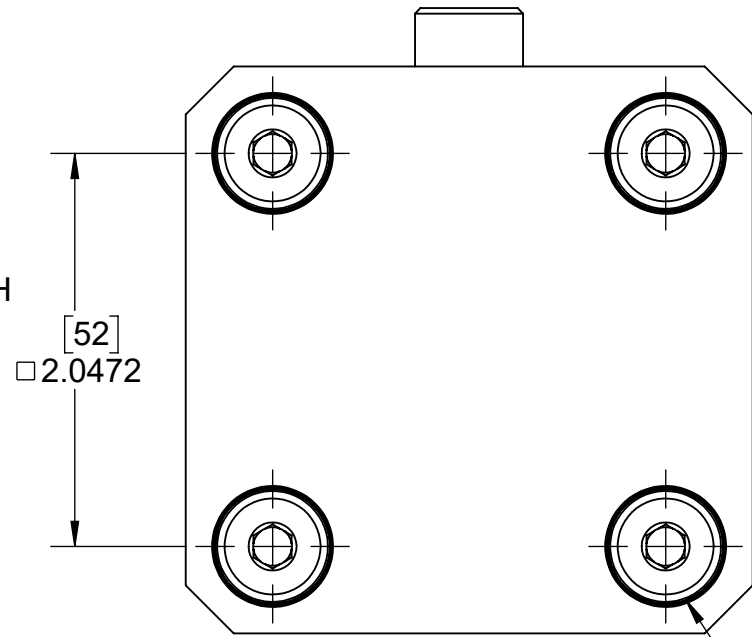

4x PS16F INCLUDED

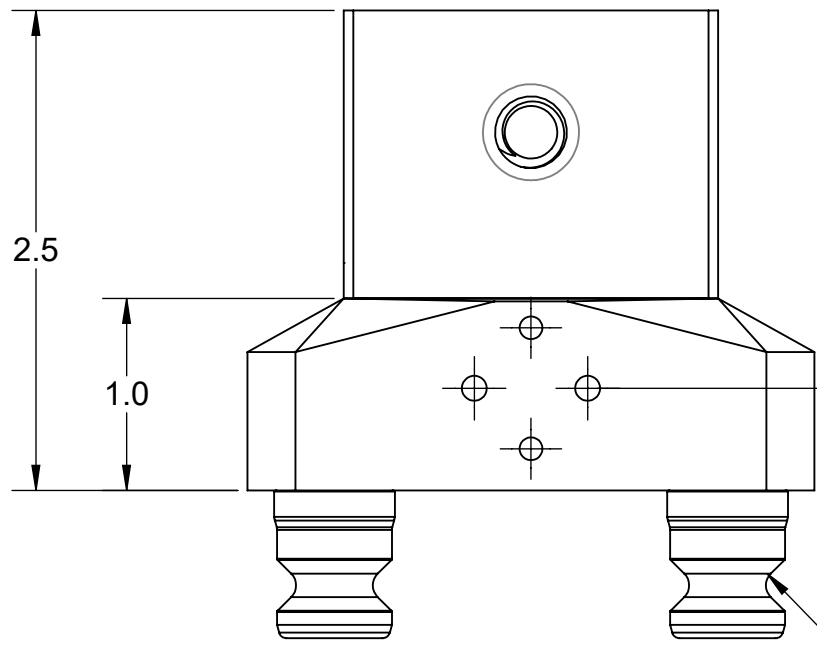
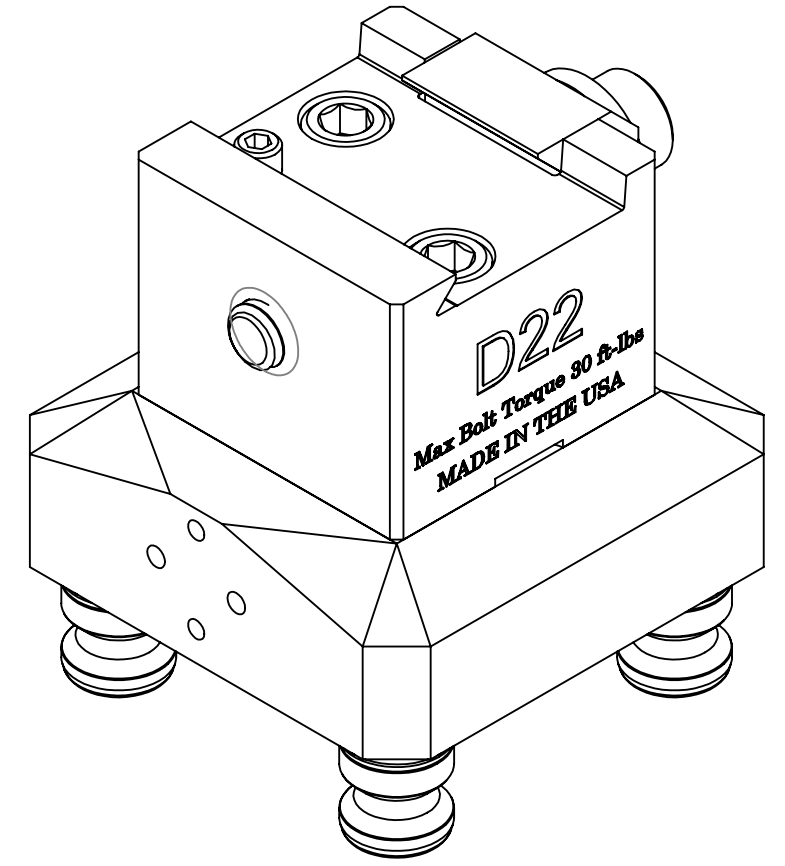

TO CENTER OF
AUTOMATION
CLEAT MOUNT

4x PS16F

INCH				
WWW.5THAXIS.COM 7140 ENGINEER ROAD SAN DIEGO, CA 92111 P (858) 505-0432				
THIRD ANGLE PROJECTION		DESCRIPTION	D22 DOVETAIL TOP TOOLING	
SIZE	PART NO.	REV		
B	A52-D22	B		
DO NOT SCALE DRAWING		SCALE 1:1	WEIGHT:	SHEET 1 OF 2

A52-D22

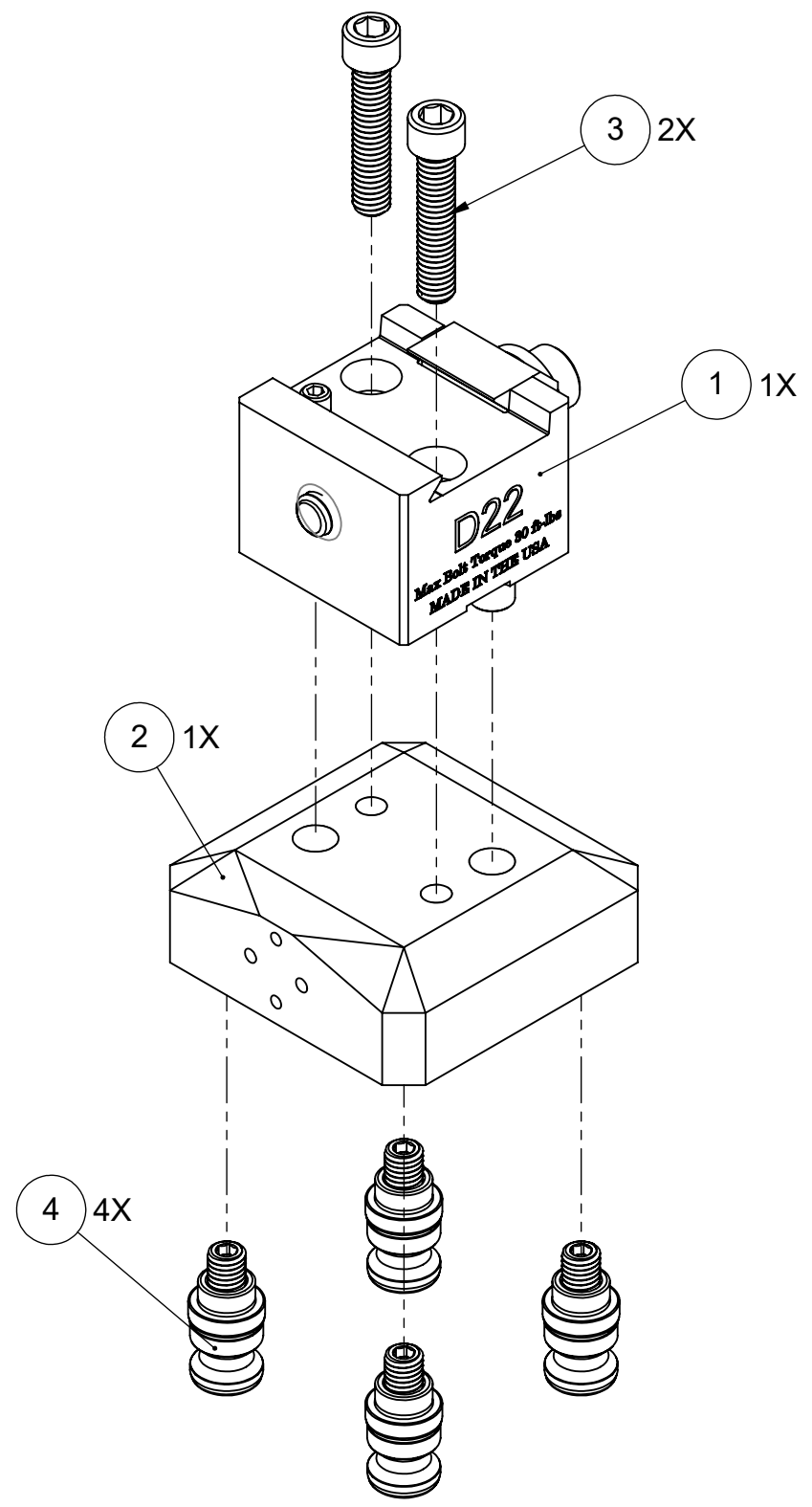

ITEM NO.	PART NUMBER	DESCRIPTION	QTY.
1	D22	DOVETAIL FIXTURE	1
2	A52-D22-1	ADAPTER	1
3	-	SOCKET HEAD SCREW, 5/16"-18x1-1/2"	2
4	PS16F	52mm PULL STUD	4
FOR REFERENCE ONLY - NOT FOR RESALE			

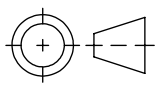
INCH			
WWW.5THAXIS.COM		DESCRIPTION D22 DOVETAIL TOP TOOLING	
7140 ENGINEER ROAD SAN DIEGO, CA 92111 P (858) 505-0432			
THIRD ANGLE PROJECTION		SIZE B	PART NO. A52-D22
		REV B	REV B
DO NOT SCALE DRAWING		SCALE 1:1	WEIGHT:
SHEET 2 OF 2			